

# CAVITATIONAL DETERIORATION OF DIESEL POWER PLANT CYLINDER LINER

Sunday BAKO<sup>\*</sup>, Abdulkarim NASIR<sup>2</sup>, Bori IGE<sup>2</sup>, Nicholas MUSA<sup>2</sup>

<sup>1</sup>Department of Mechanical, Engineering Nuhu Bamalli Polytechnic, Zaria, Nigeria,  
e-mail: s2bako@yahoo.com

<sup>2</sup>Department of Mechanical Engineering, Federal University of Technology, Minna, Nigeria

*(Received 31 August 2020, Accepted 18 September 2020)*

**Abstract:** The generating station in which diesel engine is used as a prime mover for generating electrical energy is known as diesel power plant. The cylinders liner are cylindrical component that are fixed inside the engine block. The function of the cylinder liners is to retain the working fluid and to guide the piston. Most diesel power plant uses wet-cylinder liners that are exposed to intensive cavitation. The paper aimed at studying the behavior of the cylinder liners that can lead to cavitation. The analysis involves, modeling and simulation in using Solidworks software. The analysis shows that the cylinders are subjected to harmonic vibration resulting to momentary separation of the coolant from the cylinder wall, creating a pressure difference around the coolant surface which forms air bubbles. These bubbles explode at an extreme velocity. The explosion of these bubbles release surface energy known as cavitation. The energy hammers the cylinder liner surface thereby removing minute particles of metal from the surface of the vibrating cylinder leading to cavitation deterioration. The paper hereby calls on automotive designers to take critical measures in designing of; cylinder liner, water jacket and the entire cooling system, in order to control this phenomenon.

**Keywords:** cylinder liner, cavitation, modeling and simulation

## 1. INTRODUCTION

In diesel power plants, diesel engines are used as the prime mover. The diesel fuel burns inside the engine and the products of this combustion act as the working fluid to produce mechanical energy. The diesel engine drives the alternator which converts mechanical energy into electrical energy. As the generation cost is considerable high due to high price of diesel fuel, therefore, such power stations are only

used to produce small power. Although steam power stations and hydro-electric plants are invariably used to generate bulk power at cheaper cost, yet diesel power stations are finding favor at places where demand of power is less, sufficient quantity of coal and water is not available. This plants are also standby sets for continuity of supply to important points such as hospitals, radio stations, cinema houses, telephone exchanges and schools [1].

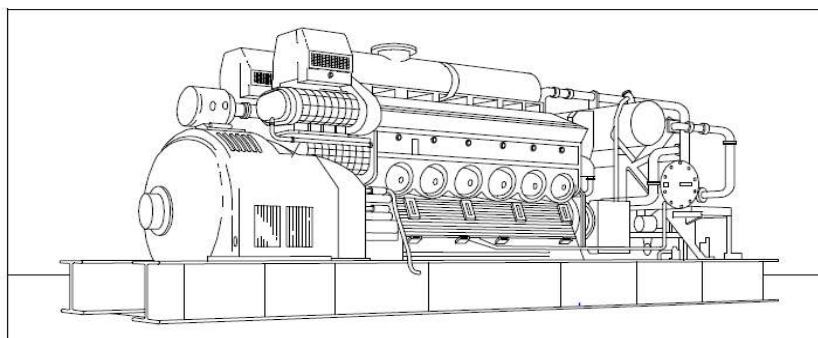

Fig. 1. A diesel power plant [2]

A cylinder liner also known as sleeve is a cylindrical component that is placed inside the engine block of an engine. It is an important part that gives a wear protective surface for piston and piston rings [3]. There are two types of liner; there are the, wet liner and the dry liner. Wet liners have contact with coolant while the dry liner does not. Among important functions of cylinder liners are to form a sliding surface, to transfer heat and to compress gases [4]. In small engines operating at a low speed, the cylinder liner and the cylinder block are cast as an integral part known as the dry liner. However in large internal combustion engines, a separate cylinder liner is used. This is done in order to; facilitates easy replacement of the liner in time of wear and tear, to less its risk of defects, to increase the power of the engine and also so that the liner can be manufactured using a superior material than of the engine block [5].

It was mentioned in [6] that the engine cylinder liner is one of the most important functional parts that make up the interior of an internal combustion engine. Cavitation of the cylinder liner is one of the main forms of cylinder liner failure [7]. With the increase of diesel engine power and high speed; cavitation of the cylinder liner becomes more and more serious [8]. Cavitation can lead to complete knock down of an engine. It usually occurs within the band extending from the top to the bottom of the liner on the thrust side and sometimes occurs on the anti-thrust side of the cylinder liner as shown in Figure 2. This paper

tends to study the structural behavior of the liner that can lead to cavitation. The paper involves modeling, simulation and animation of the wet cylinder liner to investigate the behavior of the cylinder liner that can lead to cavitation and to suggest the possible ways to combat this phenomenon.

## 2. CYLINDER LINER

Engine cylinder liners are cylindrical component that are fixed inside the engine block of an internal combustion engine. It is an important component that provides a wear resistant surface for the piston and the piston rings. The function of the cylinder liners is to retain the working fluid and to guide the piston. The cylinders are usually made from cast iron or cast steel. Since the cylinder liners have to withstand high temperature due to combustion of diesel fuel, therefore some arrangement are made to cool the cylinder [9]. Multi cylinder engine are provided with water jacket round the cylinder to cool it. The cylinder liners are of two types. A cylinder liner which does not have any direct contact with the coolant is known as dry cylinder liner. A cylinder liner which have it outer surface in direct contacted with the coolant is known as wet-cylinder liner [10]. This paper is concerned with the wet-cylinder liner and the effect of cavitation on it. Figure 2, shows an examples of some infected wet cylinder liners.



Fig. 2. Infected wet-cylinder liner

### 3. MATERIALS AND METHODS

This paper involves modeling, simulation and animation using Solidworks (2013) simulation software, to investigate the behavior of the cylinder liner and its relation to cavitation. The properties and specifications of the cylinder liner model used in this analysis are shown in Table 1 and 2 below. Figure 3 shows the summary of the research methodology.

#### 3.1. Modeling and simulation

Modeling and simulation analysis was carried out in order to investigate the impact of the engine compression and combustion pressure at the wall of the cylinder liner. The model was developed from cylinder liner catalogue with part No. WCL 40GFL [13] and was modeled using Solidworks software. For the purpose of this analysis, the spigot

length of 25% of the overall length of the cylinder liner and a spigot thickness of 50% of the cylinder wall thickness were used on the Westwood cylinder liner model in order to indicate the lower fixture point of the wet-cylinder liner in the engine block. The model and its specifications are shown in Table 1 and Figure 4 (b) respectively.

#### 3.2. Analysis and simulation

In diesel engine, heat of compression is used for ignition of the diesel fuel. The air is compressed to about 30 bars, which is compressed as the compression stroke begins and the fuel enters the cylinder at the end of compression stroke increases the temperature. When finely atomized diesel fuel is sprayed into the heated air, it ignites and burns.

**Tab. 1.** Wet-cylinder liner nomenclature and models specification

S/N	Part	Parameter	Value	Unit
1	A	Flange Depth	2.57	mm
2	B	Flange Diameter	120.35	mm
3	C	Outer Diameter	118.24	mm
4	D	Inner/Bore Diameter	111.76	mm
5	E	Spigot Diameter	115.00	mm
6	F	Spigot Length	51.10	mm
7	G	Overall Length	208.53	mm
8	H	Cylinder Height	150.66	mm



**Fig. 3.** Research methodology

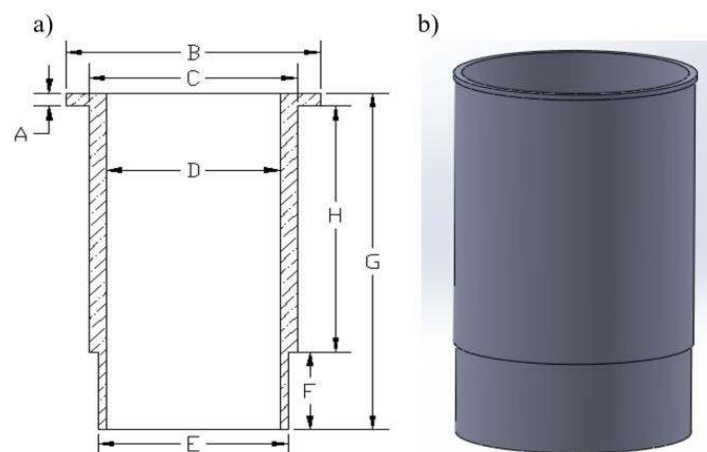

**Fig. 4.** Cylinder liners; a) nomenclature, b) solid

Typical compression pressures in diesel engines range from 30 bar to 42 bar. During combustion process the peak gas temperature in the cylinder of an internal combustion engine is of the order of 2500 K. During combustion period, the heat fluxes to the chamber walls can reach as high as 10 mW/m<sup>2</sup>. In region of high heat flux, thermal stresses must be kept below levels that would cause fatigue cracking. The temperatures must be less than about 400°C for cast iron and 300°C for aluminum alloy for water cooled engines. For air-cooled engines, these values are 270°C and 200°C respectively. The volumetric and thermal efficiency and power output of the engines decrease with an increase in cylinder and head temperature [12].

In this analysis, solidworks simulation methodology has been employed on the cylinder liner models to investigate the impact of pressure on the cylinder wall. The maximum compression pressure is considered to be 32bar in the cylinder wall. In simulating the models, the following specifications and properties of the cylinder liner material shown in Table 2, were taken into account.

Tab. 2. Material specifications and properties

S/N	Property	Value	Unit
1	Elastic Modulus	2e+011	N/m <sup>2</sup>
2	Poissons Ratio	0.32	N/A
3	Shear Modulus	7,6e+010	N/m <sup>2</sup>
4	Density	7800	kg/m <sup>3</sup>
5	Tensile Strength	182549000	N/m <sup>2</sup>
6	Yield Strength	248468000	N/m <sup>2</sup>
7	Thermal Expansion Coefficient	1.2e-005	1/K
8	Thermal Conductivity	30	W/mK
9	Specific Heat	500	kg.K

### 3.2.1 Hoop stress

The inner diameter and the thickness of a cylinder is related by;

$$t > \frac{d}{A_2}, \quad (1)$$

where:  $t$  = thickness of cylinder liner [mm],  $d$  = inner diameter of cylinder liner [mm].

The cylinder liner is exerting two pressures, which are; combustion pressure inside the Cylinder and the atmospheric pressure from outside. For the sake of this paper, the atmospheric is considered to zero.

The Hoop Stress  $\sigma_h$  on the Cylinder liner is given by:

$$\sigma_h = \frac{P_2 r_1^2 - P_1 r_2^2}{r_2^2 - r_1^2} + \frac{r_1^2 r_2^2 (P_2 - P_1)}{r_2^2 (r_2^2 - r_1^2)}, \quad (2)$$

where:  $r_1^2$  = inner radius of the cylinder liner,  $r_2^2$  = outer radius of the cylinder liner,  $P_1$  = atmospheric pressure,  $P_2$  = working pressure [13].

## 4. SIMULATION RESULTS

Figure 5 shows the Contour plots of the simulation results.

## 5. DISCUSSION

The Solidworks design insight (Figure 5 (a)) shows the part of the cylinder liner that is subjected high load impact during the combustion and the compression stroke of the engine. The gas pressure acts on some restricted areas of the cylinder liner. Displacement of the cylinder due to combustion pressure inside the cylinder is significant only in a highly rated diesel engines with thin walled wet cylinder liners [14]. This is justified by Figure 5 above.

The Solidworks animation involved exploitation of a solid body under some certain boundary condition to generate illusion of movement to illustrate the effect of the working load on the liner. During the animation process, the wall of the cylinder liner was found to be vibrating as shown in Figure 7 below. This shows that when the engine of the diesel power plant is under working operation by the action of piston inside the cylinder; it exerts pressure. This causes the liner wall to under goes harmonic vibration, due to the pressure. When the liner returns to its original shape, the water cannot follow quickly enough. As a result, small air bubbles would be created on the wall of the liner. When the cylinder liner pauses, the bubbles collapse violently on the surface of the liner as shown in Figure 6. This impact is the major causes of cavitation deteriorations on the wet-cylinder liners.

The cavitation phenomenon occurs on the outer surface of the liners during compression and the combustion stroke of the engine. When the fuel inside ignites, power is produce by the engine. This makes the liner to vibrate within the engine block due to the explosive nature of the mixture inside the cylinder; causing the creation of the air bubbles within the cylinder liner. These air bubbles implode repeatedly against the liner wall surface at a very high intensity. The collapsing of these bubbles can produces small holes in the liner leading to cylinder liner deterioration.

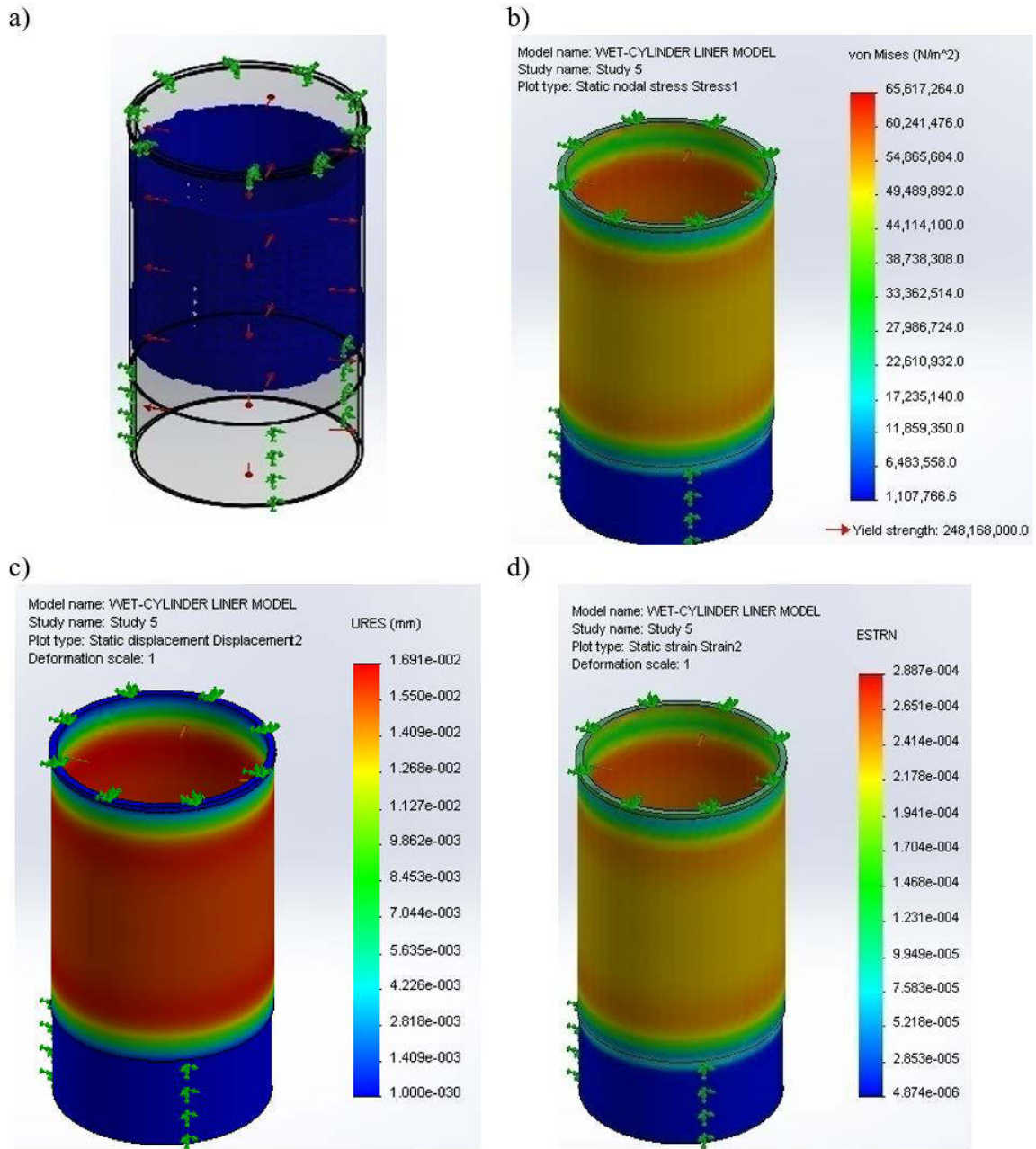

Fig. 5. Simulation results: a) design insight, b) stress plot, c) displacement plot, d) strain plot

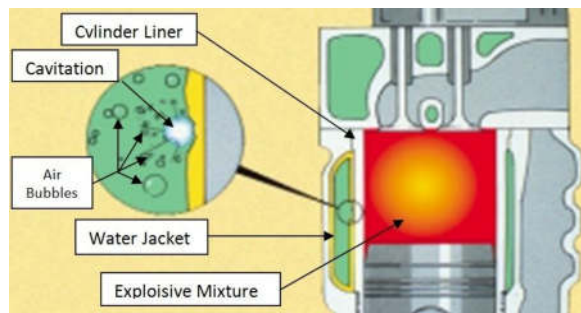

Fig. 6. Cavitation process

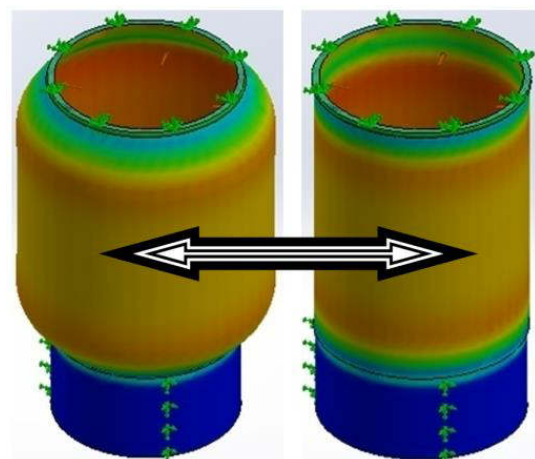

Fig. 7. Cavitation process

The animation (Figure 7) and the simulation plots (Figure 5) indicate that the maximum stress, displacement, and strain on the cylinder liner acts between the flange diameter and the spigot diameter. This implies that this region is highly exposed high load impact during the compression and the power stroke. As the results of this load impact; the region directly below flange and above the spigot diameter can say to be exposed to high cavitation deteriorations. This is one of the main causes of cavitation deterioration within region of the cylinder liner. These effects can also be justified by the infected cylinder liner in Figure 2 above. Mention that Cavitation is subjected to reduced pressures at constant ambient temperature while other factors such as changes in temperature, turbulence and velocity plays a role [12]. This cylinder wall pitting is as the result of cavitation and it is common to all diesel engines [11].

Repeated collapsing of these bubbles against the cylinder surface give rise to pronounced local damages on the surface of the cylinder liners. These local damages are cavitations corrosion/erosion and pitting [13]. It was mentioned in [15], that an increase in air bubble into the cooling system can also increase the potential for cavitation. This increased air bubbles can gets into the engine cooling system through the leak and faulty radiator cap, and this would increase the potential for bubble formation.

In-line with work done by [16], Liner deterioration is usually well defined and takes place mainly within the band extending from the top to the bottom of the cylinder liner at the thrust side and it sometimes occurs at the anti-thrust side cylinder liner. Pitting can pass through the liner wall until it gets to the combustion chamber, thereby causing complete knock down of the engine. To control these phenomena; the Supplementary Coolant Additives (SCA) can provides protection against cavitation corrosion/erosion and pitting. Cavitation can be reduced or eliminated entirely by controlling temperature and maintaining proper concentrations of cavitation mitigating additives [17].

## 6. CONCLUSIONS

The cylinder liner animation and the simulation results agreed with information formed literatures. The results show that the wet-cylinder liner is subjected to harmonic vibration. This vibration contributes to the formation of air bubbles. The continuous vibration of the liner leads to the collapsing of this air bubbles leading to cavitation deterioration of the cylinder liners. These cavitation deteriorations can be control or reduced by improved engine design and the use of Supplementary Coolant Additives (SCA).

However, the analysis shows that the cylinder liners are prone to structural failure, if the detailed

design and material selection are not properly carried out or improved. The paper hereby call on automotive designer and manufacturers to take proactive measures in the designing of the cylinder liner, water jacket and the entire cooling system. And also to develop an improve material manufacturing of cylinder. This is in order to control cavitation and to improve engine efficiency. It is hereby recommended that the following parameters should be given critical consideration during the design of the cylinder liner.

1. The expected maximum during the compression stroke.
2. The expected maximum pressure absorb by the cylinder wall during the expansion stroke.
3. Thermal expansively and conductivity of the cylinder liner material.
4. The expected maximum thermal develop on the cylinder wall during the compression and expansion stroke.
5. The maximum circumferential and longitudinal stress that would be acting on the cylinder wall.

## References

1. Rajput P.K (2009). A Text Book of Power Plant Engineering. 5th ed. Laxmi Publicatios (p) Ltd, Pp. 119-120.
2. DOE (1993). Fundamental Handbook. Mechanical Science. U.S. Department of Energy FSC-6910, Washington, D.C. 20585. pp. 1-2.
3. Bako S, Usman T, Bori I. and Nasir A (2019). Simulation of a Wet Cylinder Liner, SSRG International Journal of Mechanical Engineering. Vol. 6, No. 4. pp. 12-17.
4. Dineshkumar S and Sriprashanth V (2015). Liner Material Thermal Analysis for Diesel Engines. International Journal of Engineering Research and General Science. Vol. 6, No. 3. pp. 124-135.
5. Kumar M.A, Prasad-Rao A.A.V, Narayana-Rao J.H (2015). . Design and Analysis of Dry Cylinder Liners Used in Diesel Engines. International Journal of Science Engineering and Advance Technology. Vol. 3, No. 8. pp. 518-526.
6. Tang K.Y and Ouyang G.Y (2008). Advanced Internal Combustion Engine [M]. Beijing: National Defense Industry Press.
7. Bo Z, Ping Z, Xu G, Yin W, Xiao-Bei C, Xin-Yuan H, Xin-Rui G (2019). simulation Research on Cavitation Flow Characteristics of Highly Enhanced Diesel Engine Cooling System. Iop Conference Series: Earth And Environmental Science. Vol. 237, No. 04, pp 1-10
8. Ouyang G.Y and Bao C.H (2011). Internal Combustion Engine [M]. Beijing: National Defense Industry Publication.
9. Kurmi R.S and Gupta J.K (2004). A Text Book of Machine Design. 14th Reprint. Eurasia Publishing house (Pvt) Ltc. pp 1010-1011.
10. Divya M and Mohan-Rao P.V.J (2018). Coupled Field Analysis Of Cylinder Sleeve (Coated/Uncoated) With Respect to Piston Using MATLAB & FEA. International Journal of Advance Engineering and Research Development. Vol. 5 No.10, pp. 60-67.
11. Raja A.K, Anit P.S and Manish D (2006). Power Plant Engineering. 3rd ed. New Delhi, New International Limited Publisher. pp 250-251.

12. Andrew D and Andrew P (1995) Westwood Cylinder Liner Catalog. Droitwich. Part No. WCL 40GFL.
13. Ioannis G, Dimitrios K, Panagiotis X, Theodoros G (2009). Cavitation Erosion Of Wet-Sleeve Liners: Case Study Technological Educational Institute of Larissa, Faculty of Agricultural Technology, Department of Agricultural Machinery & Irrigation, 41110, Larissa, Greece. pp. 1-8
14. Mirajkar P.B, Kanase K.A and N.K Chhaphkane (2013). Cylinder Liner Bore Distortion Estimation During Assembly of Diesel Engine with FEA. *International Journal on Mechanical Engineering and Robotics*. Vol. 1, No. 2, pp. 66-73
15. Hutching F.R and Paul M.U (1981). Cavitation Damage to Diesel Engine Cylinder from Failure Analyais ; The British Engine Technical Reports. Ohio.
16. Yu K.Z and Jiu G,H (1981). Hammitt FG. Cavitation Erosion of Diesel Engine Liners. W.E Lay Automotive Laboratory, Department of Mechanical Engineering and Appkied Mechanics, College of Engineering, North Campus, Unversity of Michingam Ann Arbor, Mi 48109 (USA). pp 329-335.
17. Stephen G (2012). Cavitation: Causes, Effects, Mitigation and Application. Msc. Rensselaer Polytechnic Institute Hartford, Connecticut Fall. pp 1-5.

### Biographical notes



**Sunday Bako** is currently a Lecturer at the Deapartment of Mechanical Engineering, Nuhu Bamalli Polytechnic, Zaria, Nigeria. He is a registered member of the Council for Regulation of Engineering in Nigerian (COREN), Nigerian Society of Engineers and the Nigerian Institution of Mechanical Engineers. He obtained his B.Eng. in Mechanical Engineering and M.Eng. (Thermo-fluid, and Power Plant Engineering) from the Federal University of Technology, Minna, Nigeria. His research interest includes; Automotive, Thermal and Energy Engineering. His overall research goal is to add value to the existing Mechanical Engineering Products and to use Mechanical Engineering approaches, to provide the Automotive industries with needful information and tools, needed to improve engine efficiency, to reduce fuel emission and to improve vehicles safety.



**Abdulkarim Nasir** is a Professor of Mechanical Engineering with over 20 years of teaching and research experience. He received his B.Eng. degree in Mechanical Engineering and M.Eng. (Thermo-fluid, Power Plant and Automotive Engineering) from the Federal University of Technology, Minna, Nigeria. He obtained his PhD from Cranfield University, UK. His research interest includes Technoeconomic and environmental risk assessment of Gas Turbine Applications in pipelines and performance evaluation, Automotive Engineering, Fluidized Bed Combustion Technology and Energy issues. Engr. Prof. A. Nasir is a lecturer in Federal university of Technology, Minna, Nigeria and a member of ASME



**Bori Ige** is currently a Senior Lecturer with the department of Mechanical Engineering, Federal University of Technology, Minna, Nigeria. He is a registered member of ASHRAE and previously a MIT-ETT, U.S.A research fellow. He has been working on Computational Fluid Dynamics related projects since when he was studying for his PhD degree at the National University of Singapore. He has also been involved in teaching the following courses: Fluid Mechanics, Thermodynamics, Heat Transfer, Computational Fluid Dynamics (CFD), Finite Element Method (FEM), Engineering Numerical Methods and Programming. At the moment, he is more interested in the following research areas for further explorations: utilization of renewable energy, energy production from biomasses (torrefaction and gasification), indoor cooling for thermal comforts (air conditioning, natural ventilation, ventilated roofs), energy system analysis and optimization, energy storage in solar panel and wind turbines.



**Nicholas Musa** holds a PhD degree in Mechanical Engineering with specialization in Thermofluid Powerplant and Automotive Engineering from Federal University of Technology, Minna, Niger State, Nigeria. He is currently an Associate Professor in Mechanical Engineering Department, Federal University of Technology, Minna, Niger State, Nigeria. He engages in teaching Fluid Mechanics, Heat and Mass Transfer at undergraduate level, Turbomachinery, Fuels and Combustion at postgraduate level. More so, he engages in research in the field of automobile, fluid flow and renewable energy. He has published several articles in both national and international journals.

