

OVERVIEW OF THE CENTRIFUGAL METHODS OF PROVISION THE GRINDING FLUID TO THE GRINDING ZONE

Seweryn KIERAŚ^{1*}, Krzysztof NADOLNY²

^{1*} Koszalin University of Technology, Faculty of Mechanical Engineering, Department of Production Engineering, seweryn.kieras@.s.tu.koszalin.pl

² Koszalin University of Technology, Faculty of Mechanical Engineering, Department of Production Engineering

(Received 26 April 2017, Accepted 19 May 2017)

Abstract: This article presents five methods of centrifugal provision the grinding fluid to the grinding zone such as centrifugal grinding fluid supplying through the grinding spindle and through the grinding wheel, centrifugal grinding fluid provision through the channels in the grinding wheel body and grinding wheel pores, centrifugal grinding fluid provision through the channels in the body and space between abrasive segments, centrifugal grinding fluid provision through the grinding wheel divider radial channels, centrifugal grinding fluid provision method with use of zonal centrifugal grinding fluid provision system. The described characteristics were referred primarily to the conventional flood cooling method as a reference. In summary the conclusions drawn after mentioned characteristics analysis were presented.

Keywords: centrifugal, grinding wheel, grinding fluid, provision, expenditure

1. INTRODUCTION

The grinding proces involves a significant increase of the temperature value in the zone of contact between grinding wheel and workpiece. The unequal characteristics of the distribution of heat which is generated in deformable areas results in increased thermal stresses in both the grinding wheel and the workpiece [11]. To cool and lubricate the contact zone of the grinding wheel and the workpiece, the grinding fluid is used. Cooling can effectively increase the parameters that affect the grinding performance and the lubrication, while the lubrication reduces the abrasive grains blade friction with undefined geometry and often a negative angle of attack [5]. A common method of supplying the grinding fluid to the grinding zone is a flood cooling method in which the grinding fluid is pumped in use of pump and directed to the grinding zone by the nozzle with slot aperture [11]. Significant effect on the grinding fluid (in the form of the free stream supplied to the grinding zone with low velocity) efficiency is influenced by the rotating stream of air, the source of which is the rotating

grinding wheel [13, 14]. This is a phenomenon called an airbag that surrounds the grinding wheel around its circumference. When the grinding wheel is rotating with the tangential velocity of $v_s = 20$ m/s (or more) the airbag causes the deflexion and dispersion of the grinding fluid stream [6]. The airbag is a major obstacle for grinding fluid in grinding process due to it makes it difficult to interact the grinding fluid with the active abrasive grains. Moreover, the airbag restricts grinding fluid access to the grinding zone. Various airbag elimination methods have been developed, such as increased grinding fluid injection pressure, use of shoe nozzles and jet nozzles, outside the zone grinding fluid provision and different methods of centrifugal grinding fluid provision to grinding zone, what have been described in this article [7, 11]. Cooling the grinding zone using the flood cooling method is also connected with a relatively high expenditure of grinding fluid, whereas the use of centrifugal grinding fluid provision methods allows to significantly limit the grinding fluid expenditure [3, 16].

2. CENTRIFUGAL GRINDING FLUID PROVISION METHODS

Centrifugal grinding fluid supply method stands out with more efficiency in comparison to flood cooling method. Using this method is recommended during the internal cylindrical grinding process. The most beneficial effects of using the centrifugal grinding fluid supply method were noticed in grinding process of blind openings, openings of considerable length and in those situations when the area between workpiece and grinding wheel arbor is limited [11]. Currently there are several different methods of centrifugal grinding fluid supplying to the grinding area, such as centrifugal grinding fluid supplying through the grinding spindle and through the grinding wheel, centrifugal grinding fluid provision through the channels in the grinding wheel body and grinding wheel pores, centrifugal grinding fluid provision through the channels in the body and space between abrasive segments, centrifugal grinding fluid provision through the grinding wheel divider radial channels, centrifugal grinding fluid supply method with use of zonal centrifugal grinding fluid provision system.

2.1. Centrifugal grinding fluid supplying through the grinding spindle and through the grinding wheel

In case of centrifugal grinding fluid supplying through the grinding spindle and through the grinding wheel the grinding fluid is being injected by the pump through the opening in the spindle, then it flows through the radial openings to the grinding wheel pores (Fig. 1).

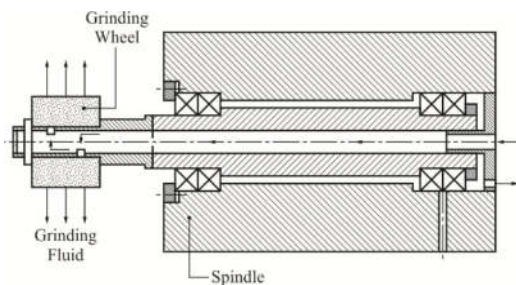

Fig. 1. The example of the centrifugal grinding wheel supplying through the grinding spindle and through the grinding wheel [11]

The grinding wheel rotation initiates the centrifugal forces which aid the grinding fluid infiltration through the grinding wheel pores. Covering the front surfaces of grinding wheel allows to supply more amount of grinding fluid to the peripheral surface of grinding wheel. Supplying grinding fluid through the grinding wheel pores is possible only while using grinding wheels with ceramic bond due to its open pores characteristics. If the size of grains is bigger and the grinding wheel structure is more open

than the grinding fluid flow rate is higher. It is due to higher level of pores volume which effects on a lower float throttling [15]. It is necessary to precisely filter the grinding fluid to avoid grinding wheel pores clogging. The acceptable value of grinding fluid mechanical impurities concentration cannot be greater than 0.3% and this value should be even lower in case of using grinding wheels with small size grains. Preservation of this condition is important due to it allows to keep the proper grinding fluid flow rate level as well as avoid the grinding wheel structural unbalancing which increases the spindle system vibrations (it occurs when the grinding wheel pores are clogged) [11]. The grinding fluids used in this method are usually mineral oils with extreme pressure additions. It is recommended to provide the grinding fluid flow rate value on the level which allows to keep the 0.05-0.15 MPa pressure inside the grinding wheel pores while using the water-oil emulsion [14].

2.2. Centrifugal grinding fluid provision through the channels in the grinding wheel body and grinding wheel pores

Centrifugal grinding fluid supply through the channels in the grinding wheel body method is being used together with cubic Boron Nitride (cBN) grinding wheels. In this method, the grinding fluid is being supplied to the ring-shape grooves located in the metal grinding wheel holder, and from this location the grinding fluid is transported to abrasive grit by special radial openings and then, thanks to centrifugal forces the grinding fluid infiltrates to the grinding wheel surface (Fig. 2) [3, 16].

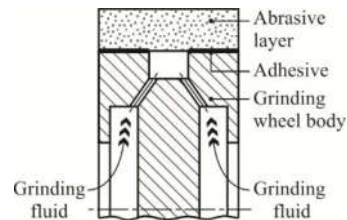

Fig. 2. The example of the centrifugal grinding fluid provision through the channels in the grinding wheel body and grinding wheel pores [3]

Described way of delivery the grinding fluid to grinding zone provides the regular supplying of grinding fluid on whole grinding wheel external surface. The most often grinding fluid used in this method are grinding oils. Authors of research [4] compared results of surface roughness obtained during the flood cooling grinding process with the results obtained during the centrifugal grinding fluid supply through the channels in the grinding wheel body and grinding wheel pores grinding process. The amount of grinding fluid distributed through the grinding wheel pores was limited to 3.0 l/min for research purposes. The grinding fluid have been transported directly to

the grinding zone which allowed to reach lower value of workpiece surface roughness in comparison to grinding process with flood cooling of 33.0 l/min grinding fluid expenditure (Fig. 3).

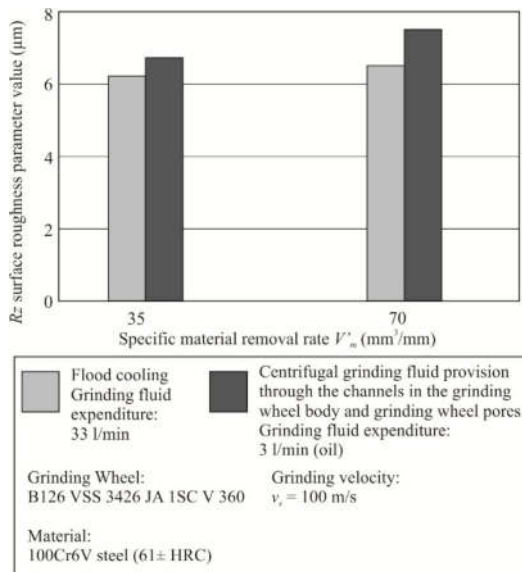

Fig. 3. R_z roughness parameter value to the specific removal rate V'_m [4]

The centrifugal grinding fluid supply through the grinding wheel pores method allows to obtain lower workpiece surface roughness value after grinding process at a significant 90% reduction of a grinding fluid expenditure [3, 16].

2.3. Centrifugal grinding fluid provision through the channels in the body and space between abrasive segments

Centrifugal grinding fluid provision through the channels in the body and space between abrasive segments method is another solution which allows to increase the effectiveness of grinding fluid supply to the grinding zone at minimization of a grinding fluid expenditure. An example of usage of this method is *T-Tool-Profil* segmental grinding wheel (Fig. 4) [20-22].

Segmental grinding wheels could consist of cubic Boron Nitride (cBN) or diamond grits connected with resin, ceramic or metallic bond. In this method the grinding fluid is being supplied to the groove located in the grinding wheel holder flange by flood nozzles of inconsiderable 0.1-0.2 MPa pressure value and then the grinding fluid is pushed due to centrifugal force through the openings located between the abrasive segments. Suitable nozzle adjustment (in the way that the grinding fluid infiltrates the contact point between the active abrasive grains and the workpiece) surface allows to obtain the favourable conditions of both cooling and lubricating the contact area between active abrasive grains and workpiece surface. The adjustment of the nozzle distance from the contact point between

the grinding wheel and the workpiece surface is done according to the grinding velocity so that the grinding fluid provision takes place ahead of angle φ value (Fig. 5).

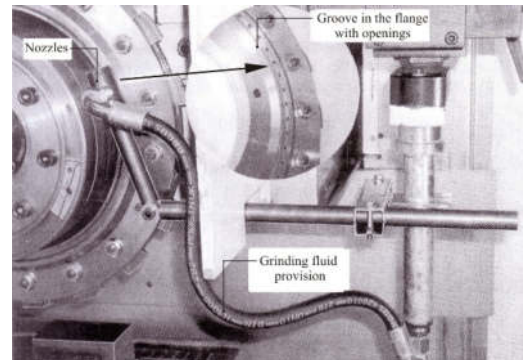

Fig. 4. *T-Tool-Profil* segmental grinding wheel with grinding fluid nozzle system which injects the grinding fluid to the groove inside the flange and through the openings (located in flange) to the space between abrasive segments [21]

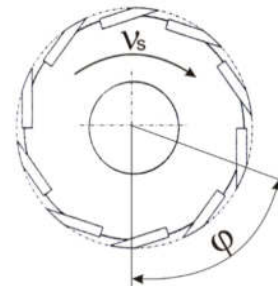

Fig. 5. Grinding fluid outflow angle φ in method using *T-Tool-Profil* grinding wheel [21]

Authors of research [22] have shown that use of *T-Tool-Profil* segmental grinding wheels allows to minimize the grinding fluid usage by 95% in comparison to the flood cooling method. Moreover using segmental *T-Tool-Profil* grinding wheels allows to reduce the value of grinding force by 70% [16, 22]. There is also another solution of grinding wheel holder where the grinding fluid provision system leads through the channels in the metal body and then through the abrasive segments [12, 19]. Designed with destination to deep ceramic materials grinding processes grinding wheel provides the grinding fluid which is supplied to the inner part of grinding wheel holder and then through the channels in the holder and abrasive segments it infiltrates directly to the abrasive grains-workpiece surface contact area (Fig. 6).

Research conducted using this type of grinding wheels shown that there is a possibility to reduce both: the residual stress σ and temperature T value on the workpiece surface in comparison to the flood cooling method [16].

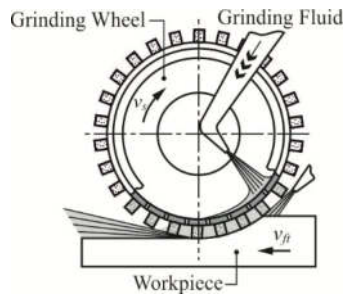

Fig. 6. General view of centrifugal grinding fluid provision system through the channels in the body and space between abrasive segments [12]

2.4. Centrifugal grinding fluid provision through the grinding wheel divider radial channels

Another effective centrifugal method of grinding fluid provision to the grinding zone is supplying it through the channels located in the divider which separates elementary parts of sandwich grinding wheel. This method could be successfully use with the sandwich grinding wheels (which consist of two or more elementary grinding wheels). In this method the grinding fluid is being provided from the inside of arbor, then through the special channels to the contact area between active abrasive grains and workpiece surface. Figure 7 shows the schematic diagram of the sandwich grinding wheel with system of centrifugal grinding fluid supplying [10].

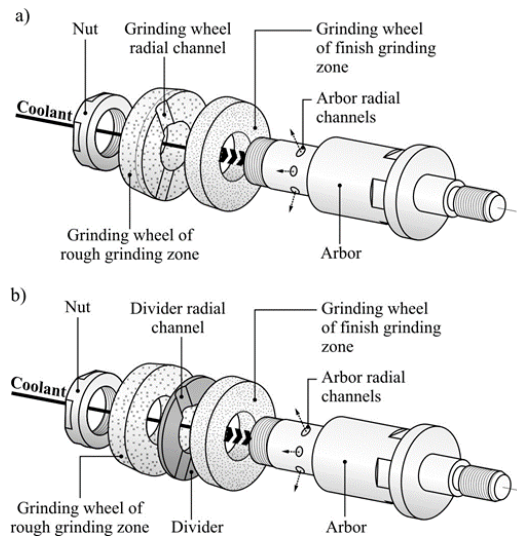

Fig. 7. Schematic diagram of the sandwich grinding wheel with system of centrifugal supplying of the grinding fluid: a) through channels formed in the grinding; b) through channels formed in a divider between elementary grinding wheels [10]

That method of supplying the grinding fluid is mostly applicable in traverse internal cylindrical grinding process. Grinding fluid flow parameters could be affected by changing the dividers the

characteristics of may vary depending on the number, shape and size of the grinding fluid delivery channels [10]. Figure 8 shows the example shapes of the located in the dividers channels which provides the grinding fluid to the grinding area.

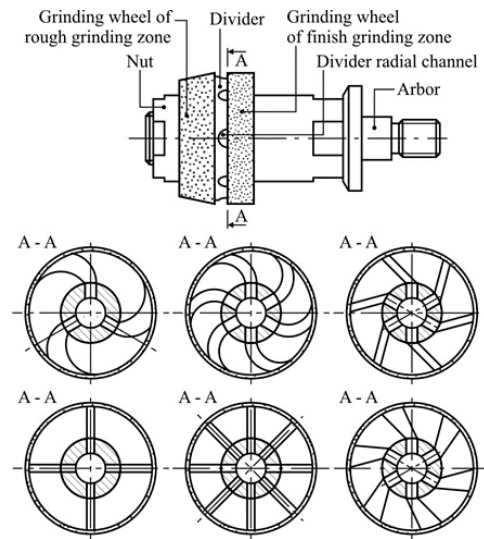

Fig. 8. Exemplary shapes of the divider channels supplying the grinding fluid to the grinding zone [10]

The greatest load of the sandwich grinding wheel in the traverse internal cylindrical grinding process occurs in the zone located between the tapered, coarse grinding area and the cylindrical, finishing grinding area, which is also the region where the grinding fluid supplying divider was located (Fig. 9).

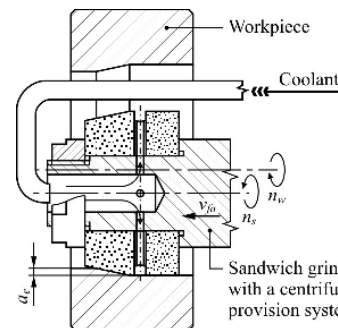

Fig. 9. Cross-section of the grinding zone using sandwich grinding wheel [10]

Research performer by authors of this solution [10] in the scope of the traverse internal cylindrical grinding process shows that the use of the sandwich grinding wheels had an influence on reducing the active grinding wheel surface cloggings. This method allows to provide more amount of supplying grinding fluid directly to the grinding zone, which had an influence on five times reduction of grinding fluid expenditure in comparison to the flood cooling method

(without the deterioration of quality and energetic parameters of grinding process). Moreover obtained results of grinding process with use of sandwich wheel shows that using this method in favourable conditions (1.0 l/min grinding fluid expenditure) allows to achieve 30% reduction (in comparison to the process performed with the zone-diverse grinding wheel and with grinding wheel without the fine grain finishing grinding zone in condition of 5.0 l/min flood cooling method) in value of the workpiece surface roughness (Fig. 10a-c). Reduction of power consumption P in grinding with sandwich wheel was inconsiderable (about 7-11%) (Fig. 10e) [10].

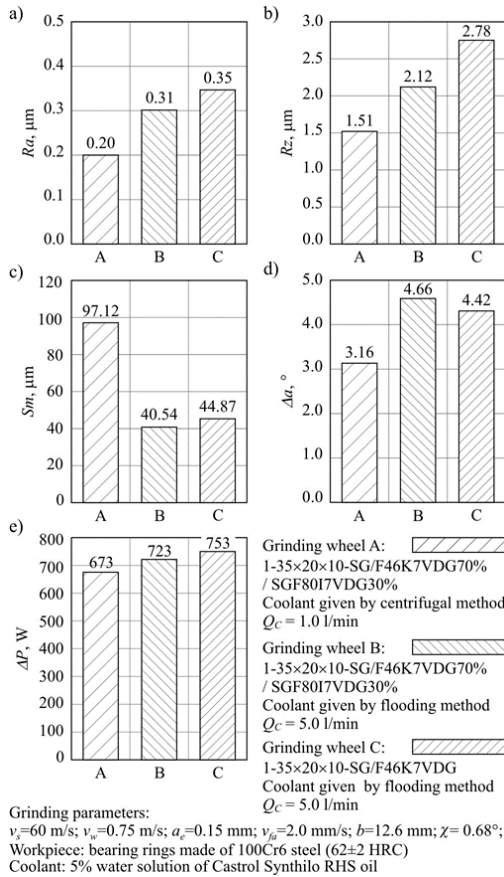

Fig. 10. Comparison of the grinding results with sandwich grinding wheel (A), grinding wheel with zone-diversified structure (B) and grinding wheel made of SGTM grains no. 46 in the entire volume (C): a) arithmetic mean deviation of the workpiece profile Ra ; b) maximum height of the profile within a sampling length Rz ; c) mean width of profile elements, within a sampling length Sm ; d) arithmetic mean slope of the profile Δa ; e) grinding power gain ΔP [10]

2.5. Centrifugal grinding fluid supply method with use of zonal centrifugal grinding fluid provision system

Zonal centrifugal grinding fluid provision system allows to direct the grinding fluid stream directly to

the contact zone between active abrasive grains and workpiece surface due to modernization of the unit which provide the grinding fluid to the grinding wheel holder and due to additional aperture which limits the grinding fluid outflow only to grinding wheel specific area. The grinding wheel was also modernized at the stage of production (radial channels have been formed inside). Figure 11 shows the schematic diagram of the zonal centrifugal grinding fluid provision system.

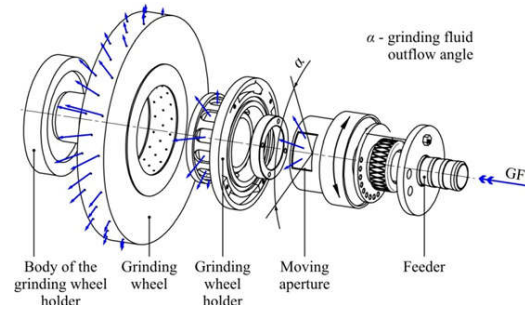

Fig. 11. Components of the zonal centrifugal grinding fluid provision system [1, 2]

The conception of the described method is that the grinding fluid fed from the supplier, flows to the grinder through the opening in the moving aperture and to the grinding wheel holder and opening inside it, then through mentioned opening to the grinding zone. Figure 12 shows the conception schematic diagram of the grinding wheel outflow during the grinding process with use of zonal centrifugal grinding fluid provision system [17].

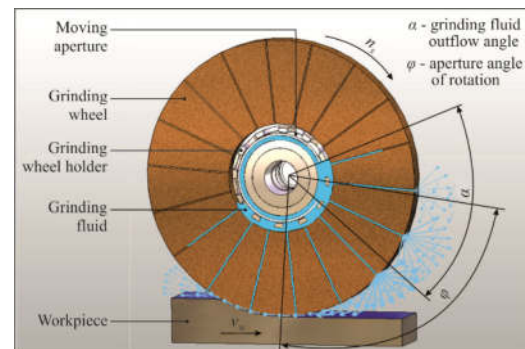

Fig. 12. The conception schematic diagram of the grinding wheel outflow during the grinding process with use of zonal centrifugal grinding fluid provision system [1, 2]

The most important function in the described system is the moving aperture, which has an opportunity to angle adjustment. Variable aperture opening angle could be set in such a way, that the grinding fluid could be provided before or directly to the contact area between active abrasive grains and workpiece surface. The authors [1, 2] have used in

their research the grinding wheels consist of white fused alumina and ceramic bond. The results they have obtained shows nearly twice the amount of grinding fluid provided into the grinding zone using the moving aperture with respect to results obtained without using it. Both the aperture angle set φ and the grinding velocity v_s , have the significant influence on the amount of the grinding fluid supplied to the grinding zone (Tab. 1).

Tab. 1. Effect of aperture angle of rotation φ on the value of normal component of the grinding force F_n (average results of five repetitions) and on grinding fluid flow rate Q_{GF} in the grinding zone [17]

Angle of the aperture φ , °	The average value of the component of the grinding force $F_{n,av}$, N	Grinding fluid flow rate in the grinding zone Q_{GF} , dm ³ /min					
		Cooling with the aperture			Cooling without aperture		
		$v_s = 7.5$ m/s	$v_s = 15$ m/s	$v_s = 30$ m/s	$v_s = 7.5$ m/s	$v_s = 15$ m/s	$v_s = 30$ m/s
0	–	0.98	0.69	0.54			
15	70	–	–	–			
30	66	0.82	0.79	0.63			
45	62	–	–	–			
60	55	0.76	0.70	0.67	570	460	390
75	47	–	–	–			
90	42	0.68	0.61	0.73			
105	56	–	–	–			
120	65	0.61	0.56	0.61			

Grinding parameters in F_n measurements: $v_s = 7.5, 15, 30$ m/s, $v_{fl} = 10$ m/min; $a_e = 0.05$ mm; $v_{fa} = 0.3$ mm per stroke; $Q_{GF} = 2.0$ dm³/min; Grinding parameters in Q_{GF} measurements: $v_s = 7.5, 15, 30$ m/s; Grinding wheel: type C (with three rows of channels)

The use of the zonal centrifugal grinding fluid provision system significantly reduces grinding fluid expenditure without significant impairing the thermal conditions in the grinding zone. Figure 13 shows a diagram of the workpiece surface temperature measurements depending on the amount of supplied grinding fluid.

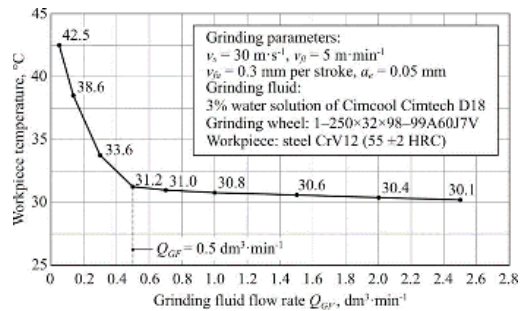

Fig. 13. The workpiece temperature variations measured 1 mm under grinding zone according to the quantity of the applied grinding fluid [17]

By analyzing the data contained in the Fig. 14, the minimum admissible amount of grinding fluid supplied to the grinding zone is 0.5 l/min and further, even fivefold increase of its output reduces the workpiece temperature by only 1°C. The use of the zonal centrifugal grinding fluid provision system has a similar, and in some cases, even lower values of the normal and tangential component of the grinding force at nearly ten times less grinding fluid expenditure compared to the flood cooling method (Fig. 14) [17, 18].

3. CONCLUSIONS

This article describes the most important centrifugal grinding fluid to grinding zone provision methods. From the analysis of the presented characteristics, the following conclusions were made:

1. The grinding process involves a significant increase of temperature in the grinding zone, therefore in most cases the grinding fluid is used to provide the stable process conditions and reproducible results.
2. There are many various types of nozzles for providing the grinding fluid to the grinding zone. Their main aim is to effectively supply the grinding fluid to the grinding zone with the greatest efficiency.
3. There are many methods of supplying the grinding fluid to the grinding area, but the progress and development of technology, as well as increasing environmental care and tendency to production costs reduction, cause that the most appropriate way is to supply possibly the least amount of grinding fluid with as much precision as possible.
4. Grinding wheels construction modifications and adjustment for use them with centrifugal grinding fluid provision methods can affect: limitation of grinding fluid expenditure in the process, reduction in the grinding force F and grinding power P consumption as well as reduction of workpiece surface roughness, reduction of grinding wheel pores clogging and overall improvement in grinding efficiency in comparison to the flood cooling method, mainly in the case of the internal cylindrical grinding process.

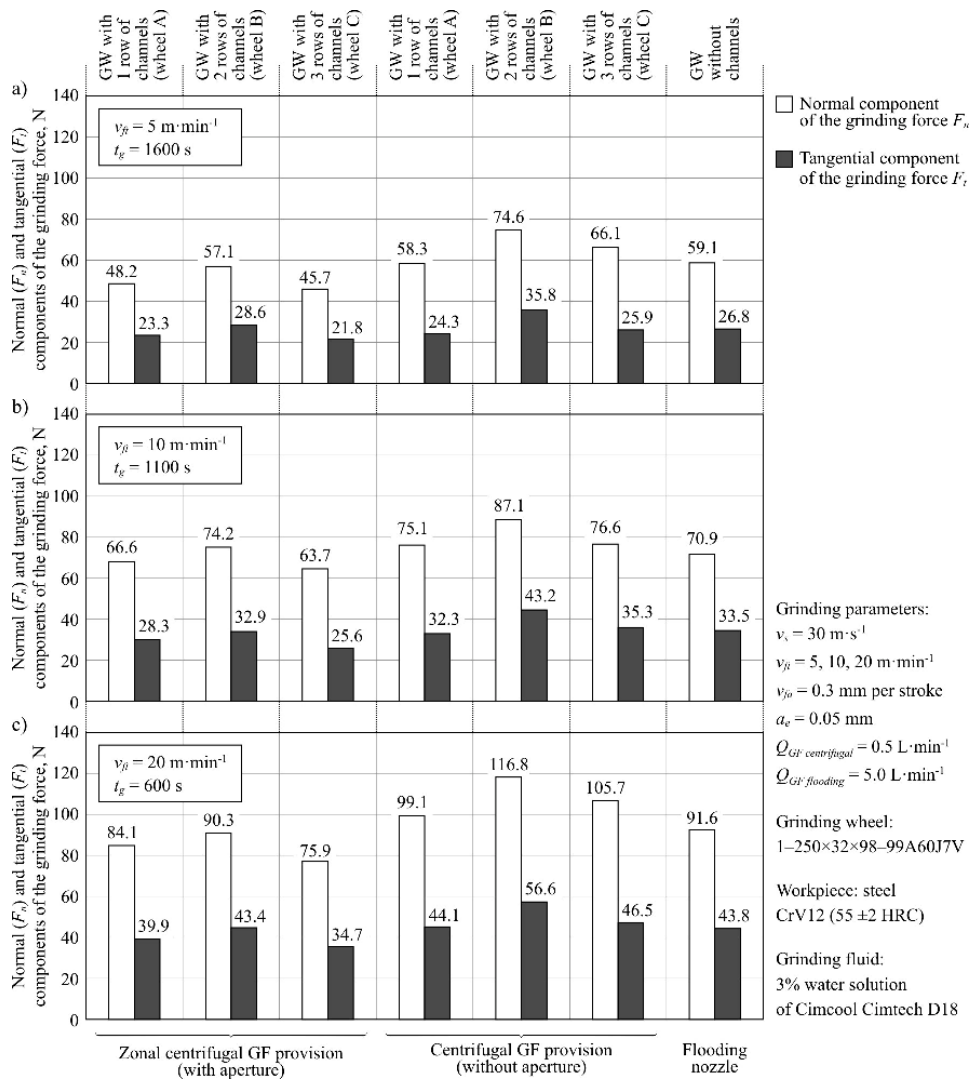

Fig. 14. Maximum values of normal (F_n) and tangential (F_t) component of the grinding force recorded in the experimental tests for the analyzed GF provision methods: a) $v_{gr} = 5 \text{ m/min}$ and $t_g = 1600 \text{ s}$; b) $v_{gr} = 10 \text{ m/min}$ and $t_g = 1100 \text{ s}$; c) $v_{gr} = 20 \text{ m/min}$ and $t_g = 600 \text{ s}$ (GW – grinding wheel) [17, 18]

References

- Karpiński T., Sieniawski J. (2005). Cylindrical grinding wheel and a mold for its preparation. Polish Patent No. PL 203295.
- Karpiński T., Sieniawski J. (2006). Grinding wheel fixture for provision of grinding fluid in grinding process. Polish Patent No. PL 203395
- Klocke F., Beck T. (1998). Gut geschmiert statt schlecht gekühlt. Kühlschmierstoffreduzierung beim cBN-Hochgeschwindigkeitsschleifen. *Werkstattstechnik*. Vol. 88, No. 9/10, pp. 400-404.
- Klocke F. (1998). cBN-Schleifscheibe senkt Kühlschmierstoff-Verbrauch. Gleiche Oberflächenqualität mit Innenkühlung. *Industrie Anzeiger*. Vol. 120, No. 37, pp. 68.
- Klocke F. (2009). *Manufacturing processes 2, grinding, honing, lapping*. Springer-Verlag, Berlin Heidelberg.
- Lauer-Schmaltz H. (1981). Hochgeschwindigkeitsschleifen mit Diamant und cBN Schleifscheiben – Einfluss. *Industrie Anzeiger*. No. 88.
- Marinescu I., Rowe W.B., Dimitrov B., Inasaki I. (2004). *Tribology of abrasive machining processes*. William andrew publishing, Norwich, New York.
- Nadolny K., Plichta J. (2011). Folding grinding tool with internal centrifugal cooling and component of this tool. Polish Patent No. 209014.
- Nadolny K. (2012). *Podstawy budowy i eksploatacji modyfikowanych ściernic z ziarnami mikrokrystalicznego korundu spiekane w procesach szlifowania otworów*. Monograph, Koszalin.
- Nadolny K. (2015). Small-dimensional sandwich grinding wheels with a centrifugal grinding fluid provision system for traverse internal cylindrical grinding of steel 100Cr6. *Journal of Cleaner Production*. Vol. 93, pp. 354-363.
- Oczóś K., Porzycki J. (1986). *Szlifowanie. Podstawy i technika*. Wydawnictwo Naukowo-Techniczne, Warszawa.

12. Ocoś E. K. (2000). *Kształtowanie ceramicznych materiałów technicznych*. Oficyna Wydawnicza Politechniki Rzeszowskiej.
13. Rapp W. (1984) Auswahl von Kühlschmierstoffen. *VDI Z.* No. 7
14. Reznikow A. N. (1977). *Abrazivnaja i almaznaja obrabotka materialov*. Masinstroenie, Moskwa.
15. Saljić E. (2013). Riefenstahl Kühlmittelzufuhr durch die Schleifscheibe beim Innen rundscheifen. *Industrie-Anzeiger*. No. 53.
16. Sieniawski J. (2013). *Badania efektywności chłodzenia w procesie szlifowania płaszczyzn z użyciem ściernic z otworami technologicznymi i strefowym podawaniem płynu*. Ph.D thesis, Koszalin.
17. Sieniawski J., Nadolny K. (2016). The effect of zonal centrifugal grinding fluid provision method on the grinding fluid demand and workpiece quality in surface grinding of steel CrV12. *Journal of Cleaneer Production*. Vol. 113, pp. 960-972.
18. Sieniawski J., Nadolny K. (2016). Experimental study on grinding force in surface grinding of steel CrV12 using zonal centrifugal grinding fluid provision system. *Proceedings of the institution of mechanical engineers part B – Journal of Engineering Manufacture*. Online first access.
19. Suto T., Waida T., Naguchni H., Rezaei M. (1990). Creep feed grinding of ceramic-matrix composites with a segmentem & perforated Wheel. *Bull. Jap. Soc. Prec. Eng.* Vol. 24, No. 3, pp. 227-228.
20. Tawakoli T. (2001). Innovatives System zum Schleifen, Abrichten und Fräsen. *Ind.Diam.Rdsch.* Vol. 34, No. 1, pp. 48, 50, 52-54.
21. Tawakoli T. (2002). Minimalmengen Kühlschmierung beim Schleifen. *Ind. Diam. Rdsch.* Vol. 36, No. 3, pp. 210-212, 215-217.
22. Tawakoli T. (2003). Minimum coolant lubrication in grinding. *Ind. Diam. Rev.* No. 1, pp. 60, 62-65.

Biographical notes



Seweryn Kieraś received his M.Sc. degree in Mechanics and Machine Design from Koszalin University of Technology in 2014. Currently a Ph.D student in the Department of Production Engineering at the Koszalin University of Technology. In his Ph.D thesis he is considering the methods of minimization of grinding fluids usage in grinding processes in case of hybrid methods of providing the grinding fluids to the grinding zone. Author of over a dozen scientific papers in mentioned scope.



Krzysztof Nadolny received his M.Sc. degree in Mechanics and Machine Design and next Ph.D (with honors) as well as D.Sc. degree in Machinery Construction and Operation from Koszalin University of Technology, in 2001, 2006 and 2013, respectively. Since 2006 he has been a researcher in the Department of Production Engineering at the Koszalin University of Technology, where currently he works as an associated professor and head of research-didactic team for production planning and control. His scientific interests focus on problems concerning machining processes and tools, efficiency, monitoring and diagnostics of machining processes as well as tribology. He has participated in 2 international and 3 national research projects, presenting results of his work at 10 international and 21 national conferences, published more than 180 scientific papers in international and national journals, book chapters, as well as conference proceedings. He is also the author of 4 monographs and 9 national patents.