

# GRINDING OF THE GEARS WITH HIGH DEPTH PROCESSING

Serghei SCATICAILOV<sup>1\*</sup>

<sup>1\*</sup>Technical University of Moldova, Faculty of Mechanical Engineering and Transport, Department of Machine Building Technology, e-mail: serghei.scaticailov@mail.ru

*(Received 10 June 2017, Accepted 12 July 2017)*

**Abstract:** The following paper presents the analysis and synthesis of technological schemes, processes, tools and equipment for processing of conical gears and precession gears with medium module. As a result, a new method which allows to intensify the process of treatment, is proposed. It ensures a required accuracy of processing. The theoretical considerations are based on the theory of gear drives, theory of involute profiles generation and precession gears, generating machine, tool design theory and machine building technology. Methods of mathematical analysis, analytic geometry, mathematical model and 3D computer model are used. The experimental research was conducted in laboratories of the Departments of Machine Building Technology and the Department of Fundamentals of Machines Design at the Technical University of Moldova, by using machines and technological equipment for machining and testing. Experimental data processing was accomplished using approximation methods and mathematical statistics.

**Keywords:** profile grinding, gear wheels, model, precision, errors

## 1. INTRODUCTION TO PROFILE DEEP GRINDING OF GEAR ELEMENTS

By its kinematics, the deep grinding differs substantially from traditional grinding methods, in particular from the pendular processing scheme. Larger material layer thickness – up to 10 mm or more removed in a single pass, in conjunction with a low workpiece feed – up to 20-40 mm/min, leads to the fact that the contact length of the abrasive tool with a workpiece and the lengths of the zones characterized by thermodynamic effects are one or two orders higher than those corresponding to traditional forms of pendular grinding.

The characteristics of deep grinding of gears made of hardened steel, due to the exact shape and large size of the contact area of the grinding wheel with the surface to be processed and its elevated sensitivity to thermal injury involves the unconditional fulfilment of the following requirements:

- during grinding process, the cavity between the adjacent tines machined in a single pass must provide a high efficiency of material removal, i.e.

3-4 times higher than, for example, creep feed grinding of the blade roots made of nickel alloys;

- the maximum allowable temperature in the cutting zone with respect to time of one deep grinding cavity should be about 1.5-2 times smaller than that corresponding to the creep feed grinding, applied to heat-resistant nickel and titanium alloys;
- the grinding wheel need to maintain the original profile while processing a maximum number of gears and multiple cavities in the period between revisions, as in gear grinding machines, with just cyclical corrections.

Thus, effective implementation of profiled deep grinding process is possible with a high productivity and minimum concomitant heating temperature (700°C). Conditions of forming the cavity found between two teeth in one or more passes with the grinding wheel are determined mainly by its cross-sectional area and the size of the contact surfaces between tool and workpiece [1-6].

The problem of finishing of conical gears was a preoccupation for the researchers in the field of manufacturing technologies. Thus, Lopatin and Plotnikova investigated the possibilities of positioning the tools and the workpiece in the case of shaving

process and grinding process to finish helical bevel gears teeth flanks [7]. They noticed that the common devices used for obtaining teeth and other shapes similar to them could be also applied in the finishing processes.

Komatsubara et al. studied the concave conical gears used in marine transmissions. They took into consideration a theoretical method of generating the concave conical gears, aiming to establish the essential dimensions of gear and tool [8]. The experiments proved a good correspondence of the principal normal radii of test gears with the values theoretically determined. Another remark was that the Hertzian contact ellipse generated in the case of concave conical gears is larger than that corresponding to the conventional conical gear.

The problem of tooth contact analysis in the case of conical involute gears was investigated by Jingliang et al. [9]. They developed a mathematical model corresponding to the conical involute gears, considering the theory of gearing and the generating mechanism.

Various aspects concerning the conical gears and methods for their machining were investigated by Radzevich [10]. The use of form grinding wheel is discussed, but especially in the case of grinding cylindrical gears.

The objective of this paper is to highlight some aspects corresponding to the deep grinding process applied in the case of conical gears, by considering the conditions specific to these gears.

When optimizing the parameters of the of creep feed grinding mode range  $S_l$ , the speed of longitudinal movement of the workpiece or grinding wheel and the cutting depth are considered; the main difficulty is to solve the problems of single-pass profiling, and imposing cuts at multi-pass profiling of gear wheels. Figure 1 shows the scheme of deep profiled grinding of gears.

The most important kinematic parameter of the process is the area of cavity section  $F_c$ , which is affected by the tool movement in a single pass.  $F_c$  depends on the size of the workpiece material cutting resistance, which is proportional to the cross sectional area of the shear layer, and accordingly, to the intensity of the thermodynamic tension in the grinding zone. In addition, the workpiece material determines the performance of the profiling process speed during the material removal (1):

$$W = F_c \cdot S_l. \tag{1}$$

Analysis of calculation of cavity section area formed in a single pass shown that  $F_c$  section increases with the number of the teeth  $z$ . The extent of this effect is negligible, i.e. with unlimited number of teeth, the decrease of the  $F_c$  is only of 5.7%. This small difference makes it possible to analyze the process of

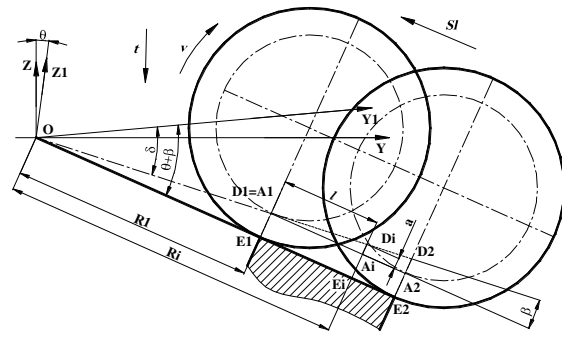

Fig. 1. The deep profiled grinding of gear

wheels formation, in a first approximation, without taking into account the number of teeth.

While forming the cavity between the adjacent teeth in a single pass, the sectional area of  $F_c$  increases from 14.95 to 229.4 mm<sup>2</sup>, this means about 15.3 times.

Accordingly, the cutting resistance increases, which is necessary to be considered when evaluating the possibility of profiling gears with large modules in a single pass.

The creep feed grinding is advisable for the first pass of the grinding wheel to determine the cutting depth. It will provide the final shapes of the teeth, or taking into account the retained allowance for finish grinding, the final shape will be obtained after thermal or chemical-thermal treatment. However, this option is rarely used due to the technical capabilities of the machine and tools, as well as to the restrictions derived from the thermodynamic conditions of the current process without forming defects.

As an example, one can see the way of change of the sectional area  $F_c$  depending on the teeth height  $h$  and cutting depth of the first pass  $t$  (Fig. 2).

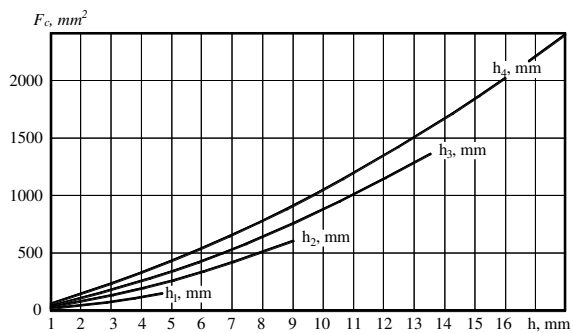

Fig. 2. Change of cross sectional area of slice F, depending on height of teeth  $h$  and grinding depth.

In turn, the required shaping power (or thermodynamic processing quality condition) depends not only on the component due to the removed slice section  $F_c$ , but also on the friction work that contributes to the overall grinding energy consumption and could be quite noticeable.

Frictional work is proportional to the contact area  $F_k$  of the grinding wheel with treated surface, which

for the deep grinding of gear is determined by the scheme shown in Figure 1.

The total area of the contact zone of the friction develops along the bottom cavity width and with a length of the contact  $s$  (equal to the contact arc  $AB$ ) and two inclined side surfaces (the dimensions of which depend on the ratio of the width  $B$  and the length  $AC$ ). Figure 3 shows the change in cross-sectional area of the cavity  $F_c$  and contact area  $F_k$  of the grinding wheel with diameter  $D = 85$  mm. Let us note that the estimated value of  $F_k$  significantly exceeds the cross-sectional area  $F_c$ : at  $h_1$  the value of  $F_k$  is greater than  $F_c$  about 55.4 times. For  $h_4$ ,  $F_c$  is still greater, but only 13.8 times.

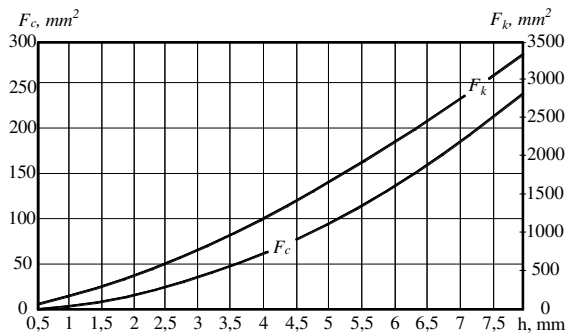

Fig. 3. Comparison of calculated values of area of slice section  $F_c$  and contact area  $F_k$  of grinding wheel.

The most closely linked feed rate and cross-sectional area (the simple correlation coefficient equals 0.838), and the grinding speed, weakly correlated with each other, kinematic and other operating parameters of the process. It indicates their statistical independence.

Thus, we can talk about the decisive influence exerted by work profile during the creep feed grinding of the gear wheels, on the parameter assigned to movement speeds. In turn, it is a function of the magnitude of the cutting depth, module and number of the teeth of the gear being processed.

The stability of the thermodynamic effects on the machined gears, due to dispersion conditions with vigorous rubbing, has, as shown by the results of the study, a decisive influence on the quality and accuracy of the profiled teeth.

From the analysis of the experimental data, one notices that, in relation to pragmatic conclusion, it is important to stabilize the thermodynamic effect of processing of the gear, and it is necessary to stabilize any controlled input parameter of the shaping process.

Such a parameter can be the value of the removed section of cavity, which is regulated by the depth of the passage. In conclusion, it should be noted that on the basis of theoretical analysis and preliminary experimental studies, there was established a fundamental possibility of implementing the process

of forming of the gear wheels profile by the creep feed grinding method.

The methodology for profile optimization in one or more passes of the grinding wheel depends on the characteristics of the toothed wheel and its handling process conditions.

It is also important to emphasize that the fundamental difference in the new process of forming gear wheels (as an analogy of profile creep feed grinding) is that it provides a high performance material removal at a lower heating of surface layer to be treated to prevent the appearance of sanding defects.

Kinematic forming of cavity implies an increased thermodynamic process intensity with an intense heating. The need to obtain an accurate profile and the minimum accumulated pitch error of machined wheels with circular grinding wheel dressing imposes stringent requirements for its durability and evenness of wear resistance for the service period.

Under these requirements, it is advisable to use a high hardness tool that becomes an additional factor able to intensify the heating process. In this connection, the abrasive tool for profile creep feed grinding of gear wheels have special requirements like the optimum combination of necessary values of its strength and durability, together with very high cutting properties, able to minimize the stresses generated by the thermodynamic process.

During profile creep feed grinding, to avoid overheating of the workpiece material, usually the soft abrasive tools with abundant cooling of the cutting area are used.

To ensure high accuracy of the formed profile, tool is subject to continuous compulsory revision with special diamond profiled rollers. In this case, during the cyclic changes, it is possible to use the tools with higher hardness and which should be reformed quickly and easily to the desired cavity profile of machined gears.

The main problem in grinding is the work of friction between the abrasive grains and the surface to be processed, its weight is up to 70-80% of the total energy costs for material removal. This is due to the fact that most of the abrasive grains, at the working surface of the grinding wheel do not participate in the cutting process. They only deform (crush) the processed material, being a significant source of heat during the grinding. The abrasive tool is the determining element in the process of grinding.

The correct assignment of the grinding wheel characteristics largely depends on character of the grinding process, level of performance, intensity of heating, tool life-time, and machining accuracy and quality.

## 2. ASSIGNING THE CHARACTERISTICS OF HIGHLY POROUS WHEEL FOR GEAR GRINDING

During the grinding, each abrasive grain and a grinding wheel as a whole interact with the processed material under extreme conditions. Under the high pressure and temperature in the cutting zone the adhesive grasps the abrasive and the work material, the mutual diffusion of chemical elements occurs. Friction between abrasive grains of the grinding wheel and the workpiece surface increases and causes the softening, breakdown of the abrasive grains and the formation of the surface layer parts with unfavorable conditions for the operation. Figure 1 shows a block diagram of the relationship of the constituent elements of the grinding wheel (grinding grain) and compares it with properties that need to be considered when selecting the tool characteristics. Under these conditions, the total thermodynamic efficiency of the grinding wheel is determined by the ability of abrasive grains on the working surface of the tool to resist the physicochemical contact phenomena and, above all, their softening and thermal degradation, as well as the ability to protect the abrasive grains from the loss of cutting properties. In accordance with the block diagram, you can define the characteristics of grinding wheels for optimal gear grinding conditions. These include:

- assignment of modified alumina as an abrasive material under high temperatures and high resistance to brittle fracture;
- grit range selection to provide the desired grinding performance with a minimum roughness of the processed surface;
- ratio of the structure (porosity) of the grinding wheel and its hardness to ensure a minimum intensity of heat and maximum durability of the tool;
- selection of a ceramic bond, which firmly holds the abrasive grains under conditions of intense heat generation and minimize the friction with the workpiece surface.

The number of grains on the working surface of the tool is connected with its voluminous content, which is regulated by a number of structures. In turn, with increasing number of structures, the volume of the pore space increases as well. The abrasive tools with number of structures more than 9 are called highly porous. Highly porous grinding wheels reduce the length of the cutting profile and increase the average distance between the grains. It lowers the cutting force and the grinding contact temperature by 40-50%. Highly abrasive vitrified wheels in combination with optimal treatment regimes, tool replacements and cooling conditions create prerequisites for the realization of the process of the profile creep feed grinding of gears. It also makes the

favorable prospects of expansion of areas of effective application of new technology in the processing of complex-cutting and rolling tools, shanks turbine and compressor blades of the heat-resistant titanium alloys and other components in complex structural and technological performance.

For the structure numbers 12-20, the amount of pore space should be 55-75% of the volume of the instrument. It depends on the content of ceramic binder required to obtain the desired hardness. Without the introduction of the abrasive solid mass porogens, it would be technologically impossible to provide the high structure with a low content of abrasive grains. The porogen introduced in the abrasive mass must, on the one hand, be sufficient to provide uniform tool by volume formability and strength forms at all stages of manufacture (including dimensional stability at high-temperature sintering). On the other hand, the blowing agent during heating can chemically react with the ceramic binder and abrasive grains, and change their properties. The most common production technology of highly porous abrasive tool uses artificial (naphthalene) or natural (ground fruit pits) products to obtain the gas. While bursting under the pressure on the surface of the tool they form a porous volume with random shape, size, and orientation. At the same time the escaping gases destroy the bridges of communication between the abrasive grains, reducing the hardness and durability of the wheel. Prerequisites for the formation of an inhomogeneous structure of the volume of abrasive grinding wheel with fluctuations of density (and, accordingly, with the imbalanced mass) and hardness are created in the process.

Depending on the requirements of technological and operational characteristics of grinding wheels, corundum, aluminum silicate or glass hollow microspheres are used as the blowing agents (individually and in various combinations). They have a regular geometrical shape of a sphere with a thin wall thickness of about 5.1 microns depending on the composition and size. The microspheres participating in the creation of a durable frame “grains-microspheres-bunch-air” can well withstand high static load in the pressing tool. If such a bead is located on the working surface of the grinding wheel, it is easily split during grinding and form an additional cutting edges. Non-burnable blowing agents may be doped, if necessary, with burnable blowing components, for example, ground olive seeds or fruit seeds of various sizes. The structure of abrasive grains, ligaments, and framework of various in shape and size artificial pores, moulded with the new technology can significantly improve the technological properties and performance of the high-porosity tools.

The optimal choice of the characteristics of the grinding wheel takes into account size of the grain,

hardness and structure of the instrument based on unconditional restrictions to ensure the set parameters on material removal rate, the roughness of the treated surface of the part and the thermal stress in the cutting zone. Optimization of characteristics of a highly porous material takes into account, in addition to these restrictions, the need for increased durability and efficiency of the grinding process.

If you are working on the surface of the grinding wheel, which can collect the chips, the increased cutting power tool may cause the "brining", that is, the loss of cutting properties by filling the pores with chips. In addition, the selection of the optimal ratio of "grain-hardness-structure" by optimizing the composition of the abrasive mass and ceramic binder can provide grinding conditions for grinding wheel wear process to be in a self-sharpening mode, i.e. to maintain a constant cutting ability for a long time processing at optimum wear resistance and dimensional stability.

### 3. SELECTION OF AN ABRASIVE TOOL FOR GRINDING OF GEAR PROFILE

The abrasive tool is a determining element in the process of grinding. The correct assignment of the grinding wheel characteristics largely depend on character of the grinding process, the level of performance, the intensity of heat, tool life-time, and machining accuracy and quality.

Work reduction in grinding – this is mainly the work of friction between the abrasive grains and the surface to be treated, its weight is up to 70-80% of the total energy costs for material removal. This is due to the fact that most of the abrasive grains, which are at the working surface of the grinding wheel do not participate in the cutting process, they only deform (crush) the processed material, as a significant source of heat during grinding. In this regard, the use of the grinding wheel with a reduced amount of abrasive grains and volume, i.e. with high number of structures, is a main factor of reducing friction during grinding process and, consequently, the intensity of heat. It is natural to expect that fewer grains on the working surface of the tool will increase the number of those that actively participate in the work, and their potential to remove material will be used more efficiently.

### 4. CONCLUSIONS

The theoretical analysis showed that the main technical difficulty of implementing the grinding process into profiling of gear wheels, is extremely unfavorable combination of large sections of the removed material  $F_c$  and more than an order of magnitude larger contact area  $F_k$  of wheel with machined surface profile. Dimensions  $F_c$  and  $F_k$  determine respectively the two main characteristic

components of the cutting operation: removal of the workpiece material and the work of the friction. Both kinematic components responsible for the thermodynamic strength of the cutting process and the stability of its course are very dependent on the gear unit element and the number of passes.

Calculations show that for forming gears in a single pass of the grinding wheel, the dominant in the energy balance of cutting process is material removal operation and the controlling factor is the cutting resistance of the processed material. When profiling in two or more passes, the proportion of frictional work increases with each pass, which intensifies the unfavorable development of thermal phenomena. The analysis showed that the cutting tool for the purpose of a deep profile grinding of gears must simultaneously have: strength increased to 25-45 to overcome the resistance of the material being processed, high wear resistance for the cyclical change of conditions and to ensure minimum friction between the profiled cavity and a high quality surface finish. This set of properties is achieved by a balanced ratio of grain hardness, structure and brand ceramic bond of the grinding wheel.

Bauman has developed a new technology for manufacturing of highly porous grinding wheels, in which the structure is formed with the use of environmentally friendly, non-burnable blowing agents in the form of microspheres of different composition, size and properties. New manufacturing technology of highly porous abrasive tool is original, especially, its composition of the abrasive mass. Optimization of the various compositions and quantity of blowing agents in the abrasive mass provides a tool for the desired properties of hardness, porosity (number of structures), tensile strength and mass unbalance (imbalance). Selection of porogens must meet environmental safety requirements, as the abrasive mass in general should guarantee good processing properties including increased raw strength, minimum values of tool deformation when dried and sintered in high temperature, and hardness range of the dispersed volume. Proposed composition of highly porous abrasive mass is complex, multicomponent and polymorphic. Its structure can consist of up to 10-12 components: abrasives, pore formers and binders; different in their chemical composition, density, shape, size and electrostatic properties. For example, the density within the highly porous abrasive component may range from 0.3 to 4 g/cm<sup>3</sup>, which is more than 10 times. Its dispersity, however, may range from 0.01 up to 0.5 mm or even more. To produce these conditions, a homogeneous mass without destruction of abrasive during mixing of blowing agents in the form of thin-walled microspheres was necessary. Thus, a special sequence of time and mixing of each component and the total

intermediate mixing time depending on the composition of highly porous abrasive mass was developed. This is also the originality of the new environmentally friendly technology of production of highly porous abrasive tool.

#### Symbols

$F_c$	– area of cavity section, mm <sup>2</sup>
$F_k$	– contact area of grinding wheel, mm <sup>2</sup>
$h$	– height of teeth, mm
$s_l$	– speed of longitudinal movement, mm/min
$t$	– depth of cutting, mm
$l$	– length of tooth, mm
$R_i$	– inner radius of toothed wheel, mm
$R_t$	– arbitrary position of tool on machined tooth, mm
$v$	– peripheral speed of grinding wheel, m/s

#### Greek letters

$\vartheta$	– angle of precession, °
$\delta$	– angle of conical axoid, °
$\beta$	– angle of conicity, °

#### Acronyms

O X Y Z	– fixed coordinate system
O X1 Y1 Z1	– mobile coordinate system

#### References

1. Bostan I., Mazuru S., Scaticailov S. (2013). Technologies for precessional planetary transmissions toothing generation. *TEHNOMUS Journal*, Vol. 20.
2. Bostan I., Mazuru S., Vaculenco M., Scaticailov S. (2012). Issues technology manufacturing precessional gears with nonstandard profile generating. IX International Congress “Machines, Technologies, Materials 2012”, Varna, Bulgaria.
3. Komatsubara, H., Mitome, K., Ohmachi, T., Watanabe, H. (2002). Development of Concave Conical Gear Used for Marine Transmissions (2nd Report, Principle of Generating Helical Concave Conical Gear). *JSME International Journal Series C*, Vol. 45, No. 2, pp. 543-550.
4. Jingliang H.E., Xutang W.U., Yahui C.U.I., Gang N.I.E. (2006). Tooth contact analysis of conical involute gears, *Chinese Journal of Mechanical Engineering*, Vol. 19, No. 1, pp. 105-108.
5. Mazuru S., Vlase A., Scaticailov S. (2014). *Processing technologies on machine tools for machining gears*. Tehnica-U.T.M, Chişinău. (in Romanian)
6. Radzevich S.P. (2010). *Gear cutting tools. Fundamentals of design and computation*. Taylor and Francis Group, Broken Sound Parkway.
7. Botnari V., Mazuru S. (2014). Influence of processing parameters on the quality of the superficial layer after processing surfaces with plastic deformation processes. *Applied Mechanics and Materials*, Vol. 657, pp. 147-152.
8. Mazuru S., Casian M. (2014). Theoretical and experimental aspects concerning elastic behavior in the grinding technological system. *Advanced Materials Research*, Vol. 1036, pp. 292-297.
9. Casian M., Mazuru S. (2014). A study concerning the workpiece profile after grinding process of precessional gear wheels, *Advanced Materials Research*, Vol. 1036, pp. 286-291.
10. Lopatin B.A., Plotnikova S.V. (2016). Finishing of the Helical-bevel Gear Teeth Flanks. *Procedia Engineering*, Vol. 150, pp. 889-893.

#### Biographical note



**Serghei Scaticailov**, MSc in Machine Building Technology (1996) and DSc (1998) at the Technical University of Moldova. Lecturer at the Department of Machine Building Technologies since 1996. Co-organizer of the TMCR conferences in 1999, 2001, 2003, 2005, 2009, 2011 and 2014. Participant in national and international conferences.

He published 28 scientific papers, 2 books and holds 6 patents. Participant in the implementation of national and international research projects.